

SLIP RING

ENDO

You Tube

ENDO KOGYO 



SLIP RING

ENDO KOGYO offers a wide variety of slip rings from fine current(0.2A) to large current (more than 600A) to satisfy many routine customer needs.

We would like to respond your particular requirement.

- Multiplex slip ring for communication and power supplying
- Large current and large capacity type
- Parts supplying

Slip ring for communication and control



SRP series
P.3~8

High voltage slip ring

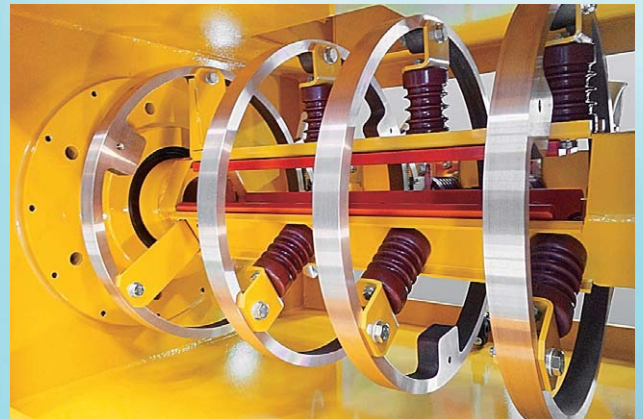

Slip ring for power and control



SR series for indoor
P.9~10



SR series for outdoor
P.11~12

Main applications

- Industrial machines
- Machine tools
- Wrapping machines
- Food processing machines
- Medical and health care products
- Measurement instruments
- Game machines
- Communication machines
- TV cameras and monitors
- Printers
- Turn tables
- Robotics
- Audio instruments

SRP SERIES

- Brushes enable to give communication without interruption or delay.
- Relatively light and compact in design
- Easy to install and service

SRP

■ Materials

- Brush : Gold alloy
- Ring : Copper alloy / the hard gilt
- Body : Aluminum
- Shaft : Aluminum

SRP-CN4-F for Flat cable



■ Specification

Compliance DeviceNet

Contact resistance Red and Black poles 0.06Ω White and Blue poles 0.10Ω(initial value)

Transmission speed Max 500Kbps (DeviceNet)

Electric construction For signal, 2 poles 0.3A (White and Blue poles)
For power, DC24V 2 poles 5A (Red and Black poles)

Rotational torque Less than 0.03N/m (Less than 300gf•cm)

Allowable radial load 13N (1.3kgf)

Allowable thrust load 13N (1.3kgf)

Protective construction IP4X

Cable Flat cable 1m from shaft side and body side

Mass 250g

SRP-CN4-R for round cable



■ Specification

Contact resistance Red and Black poles 0.06Ω White and Blue poles 0.10Ω(initial value)

Electric construction For signal, 2 poles 0.3A (White and Blue poles)
For power, DC24V 2 poles 5A (Red and Black poles)

Rotational torque Less than 0.03N/m (Less than 300gf•cm)

Allowable radial load 13N (1.3kgf)

Allowable thrust load 13N (1.3kgf)

Protective construction IP4X

Cable VCTF 0.75mm²×4c 1m from shaft side and body side

Mass 250g

Outside dimension SRP-CN4-F SRP-CN4-R (mm)

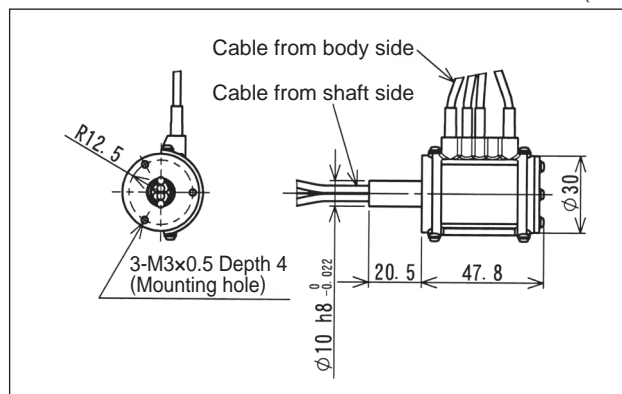

SRP-DN5



■ Specification

Compliance DeviceNet (thin cable)

Contact resistance Red and Black poles 0.11Ω White and Blue poles 0.21Ω
Shield 0.12Ω (initial value)

Transmission speed Max 500Kbps (DeviceNet)

Electric construction For signal, 2 poles 0.3A (White and Blue poles)
For power, DC24V 2 poles 3A (Red and Black poles)
For shield, 1 pole

Rotational torque Less than 0.03N/m (Less than 300gf·cm)

Allowable radial load 13N (1.3kgf)

Allowable thrust load 13N (1.3kgf)

Protective construction IP4X

Cable DeviceNet thin cable 1m from shaft side and body side

Mass 250g

SRP-CL4



■ Specification

Compliance CC-Link

Contact resistance Blue, White and Yellow poles 0.10Ω Shield 0.05Ω (initial value)

Transmission speed Max 10Mbps (CC-Link)

Electric construction For signal, 3 poles 0.3A (Blue, White and Yellow poles)
For shield, 1 pole

Rotational torque Less than 0.03N/m (Less than 300gf·cm)

Allowable radial load 13N (1.3kgf)

Allowable thrust load 13N (1.3kgf)

Protective construction IP4X

Cable CC-Link cable 1m from shaft side and body side

Mass 250g

Outside dimension SRP-DN5 SRP-CL4 (mm)

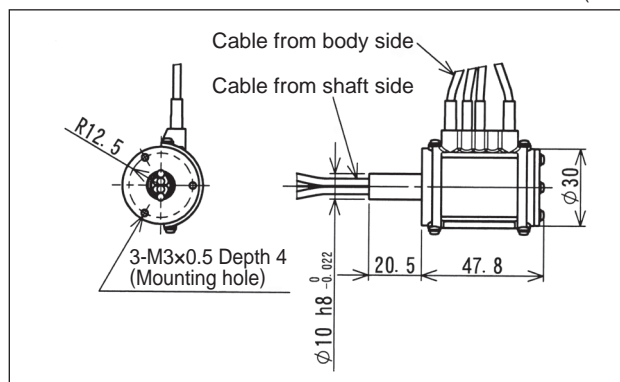

■ Common specifications for SRP series

Rotational direction	CW-CCW endless
Rotational life	30 million maintenance free
Tensile strength	3N
Allowable rotation	0-400min (rpm)
Vibration tolerance	Less than 5G
Environment	No dew condensation / Less than elevation 1,000m
Mounting direction	Free
Time rate	Continuously

SRP SERIES

SRP-MLII-3



■ Specification

Compliance MECHATROLINK-II

Transmission rate Transmission speed 10Mbps Transmission period 250μs
MECHATROLINK-II

Electric construction For signal, 2 pole 0.3A (Red and Black poles)
For shield, 1 pole

Rotational torque Less than 0.03N/m (Less than 300gf·cm)

Allowable radial load 13N (1.3kgf)

Allowable thrust load 13N (1.3kgf)

Protective construction IP4X

Cable MECHATROLINK-II cable 1m from shaft side and body side

Mass 250g

Outside dimension SRP-MLII-3 (mm)

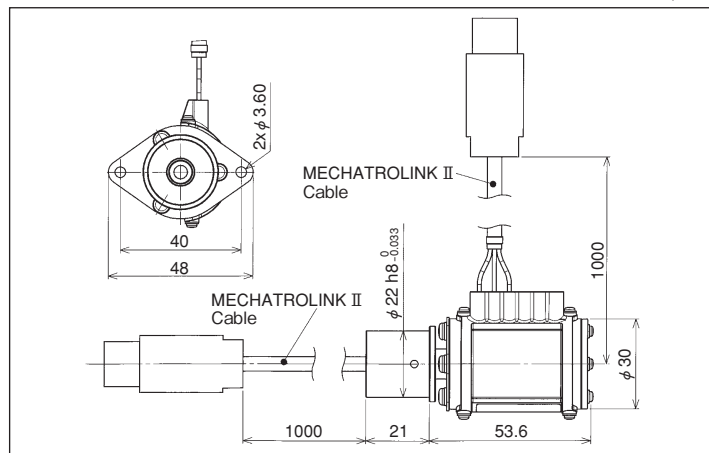

SRP-EN5e for EtherNET



■ Specification

Compliance CAT5e(TIA/EIA-568-B-2-2001)

Electric construction For EtherNET, 8 poles For shield, 1 pole

Rotational torque Less than 0.03N/m (Less than 300gf·cm)

Allowable radial load 13N (1.3kgf)

Allowable thrust load 13N (1.3kgf)

Protective construction IP4X

Cable Double shield STP CAT5e strand cable 1m from shaft side and body side

Mass 260g

Outside dimension SRP-EN5e (mm)

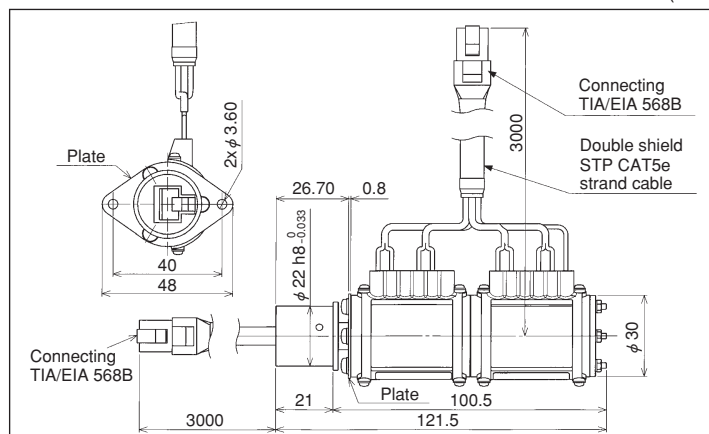

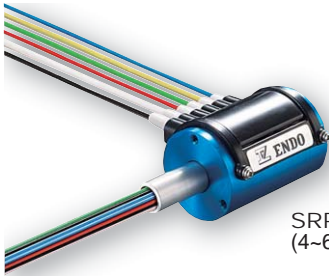
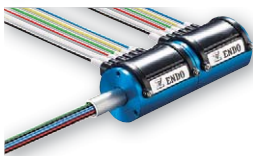
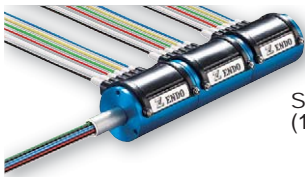
SRP-3003 SERIESSRP-300306S
(4~6 poles)SRP-300312S
(8~12 poles)SRP-300318S
(14~18 poles)**■ Specification****Compliance** RS-422/485/232C**Contact resistance** 0.16Ω (Initial value)**Insulation resistance** DC500V, more than 50MΩ**Electric construction** For signal, AC·DC250V 4~18 pole 0.3A (Only even poles)**Rotational torque** Less than 0.03N/m (Less than 300gf·cm)**Allowable radial load** 13N (1.3kgf)**Allowable thrust load** 13N (1.3kgf)**Protective construction** IP4X**Cable** 0.3mm²m from shaft side and body side**Mass** 110 g (6 poles), 260g(12 poles) 350g(18 poles)

Dimension for SRP-3003 SERIES (mm)

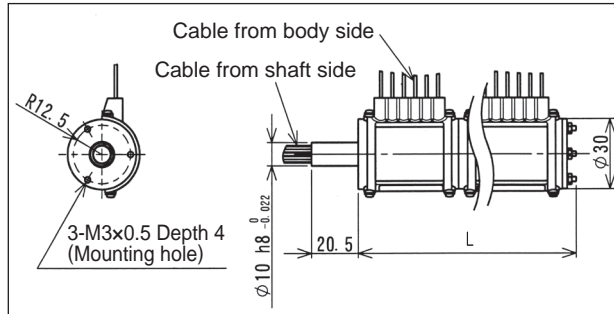

Number of poles	L Length (mm)
4~6 poles	47.8
8~12 poles	94
14~18 poles	138

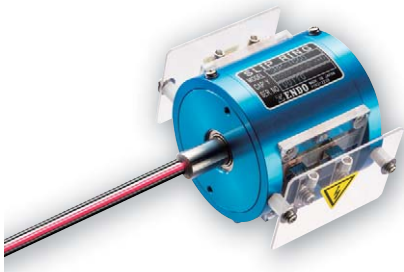
SRP-TC60 Thermocouple**■ Specification****Insulation resistance** More than DC500V 100MΩ**Thermocouple measurement** Type-K Compensation lead wire 2poles**Dielectric strength** AC1500V 1 minute**Electric construction** AC250V 15A 2 poles**Rotational torque** Less than 0.03N/m (Less than 300gf·cm)**Protective construction** IP4X**Cable** 15A KIF 1.25mm² and Type-K Compensation lead wire VX-G-VVF 1P×24/0.2 0.75mm² more than 0.5m from shaft side only**Mass** 240g

Outside dimension SRP-TC60 (mm)

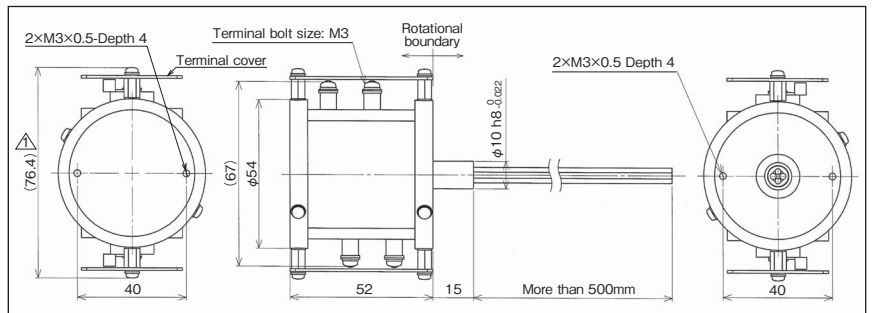
**■ Common specifications for SRP series**

Rotational direction	CW-CCW endless
Rotational life	30 million maintenance free
Tensile strength	3N
Allowable rotation	0-400min (rpm)
Vibration tolerance	Less than 5G
Environment	No dew condensation / Less than elevation 1,000m
Mounting direction	Free
Time rate	Continuously

SRP SERIES

SRP-CL4H



CC-Link

■ Specification

Compliance CC-Link

Contact resistance Blue, White and Yellow poles 0.2Ω Shield 0.1Ω(Initial value)

Transmission speed Max 10Mbps(CC-Link)

Electric construction For signal, 3 poles 0.3A (Blue, White and Yellow poles)
For shield, 1 pole

Rotational torque Less than 0.1N·m

Protective construction IP4X

Cable CC-Link cable 1m from shaft side and body side

Mass 1100g

Outside dimension SRP-CL4H

(mm)

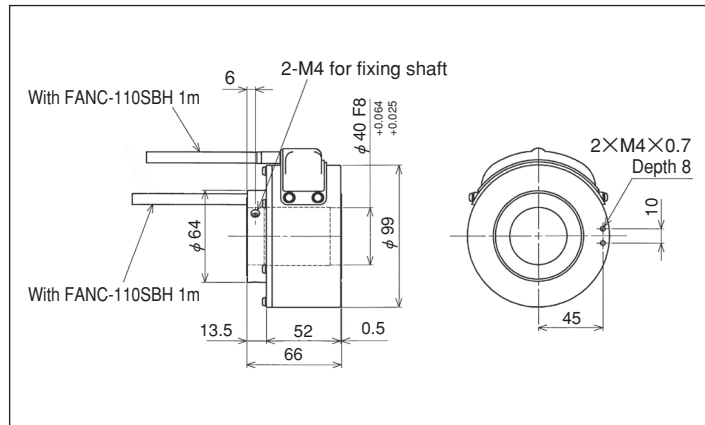

SRP-CL4HP



CC-Link

■ Specification

Compliance CC-Link

Contact resistance Blue, White and Yellow poles 0.2Ω Shield 0.1Ω(Initial value)

Transmission speed Max 10Mbps(CC-Link)

Electric construction For signal, 3 poles 0.3A (Blue, White and Yellow poles)
For power, AC250V 5A and ground cable
For shield, 1 pole

Rotational torque Less than 0.1N·m

Protective construction IP4X

Cable CC-Link cable 1m from shaft side and body side

Mass 1100g

Outside dimension SRP-CL4HP

(mm)

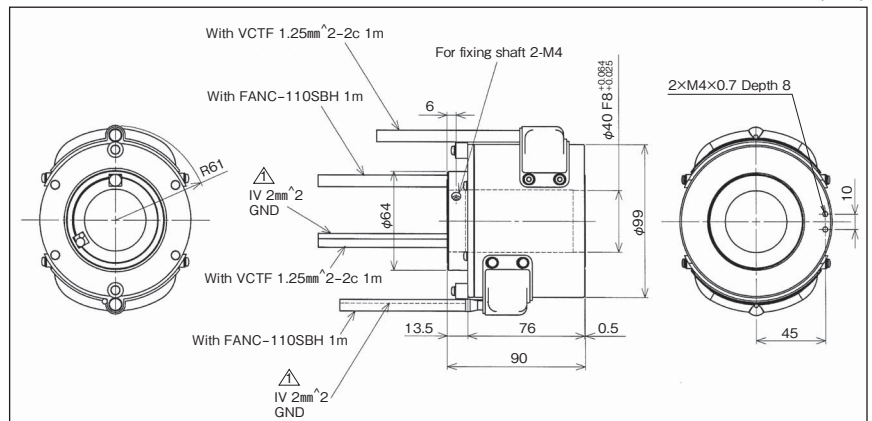

SRP-10003 SERIES

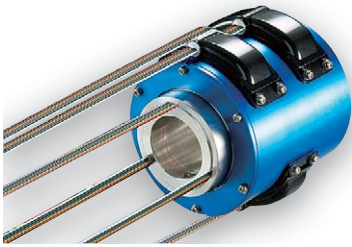

Number of poles	L Length(mm)
4 poles	66
6 poles	66
12 poles	90
18 poles	114

■ Specification

Compliance RS-422/485/232C

Contact resistance 0.2Ω (Initial value)

Electric construction For signal, AC•DC250V 4~18 poles 0.3A (Only even poles)

Rotational torque Less than 0.1N/m

Protective construction IP4X

Cable 0.3mm² cable 0.5m from shaft side and body side

Mass 1100g (6 poles) 1400g (12 poles) 1800g (18 poles)

Outside dimension SRP-10003 SERIES (mm)

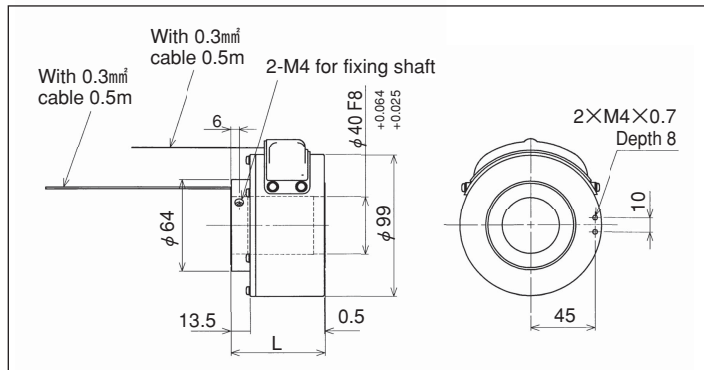

SRP-13575 SERIES

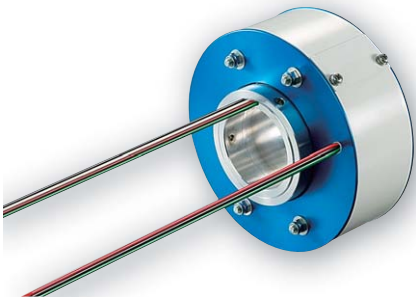

Number of poles	L Length(mm)
4 poles	64.5
6 poles	75.5
12 poles	108.5
24 poles	174.5
36 poles	240.5

■ Specification

Contact resistance 0.05Ω (Initial value)

Electric construction For power, AC250V 7.5A (4~12 poles) 5.0A (4~24 poles)
2.5A (4~36 poles)

Rotational torque Less than 0.1~2.0N•m

Protective construction IP4X

Cable 1.25mm² cable 0.5m from shaft side and body side

Mass 1500g (4 poles) ~ 5000g (36 poles)

Outside dimension SRP-13575 SERIES (mm)

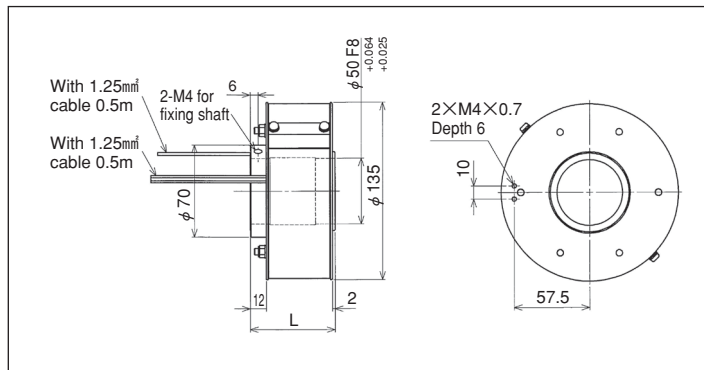

■ Common specifications for SRP series

Rotational direction	CW-CCW endless
Rotational life	30 million maintenance free
Tensile strength	3N
Allowable rotation	0-400min (rpm)
Vibration tolerance	Less than 5G
Environment	No dew condensation / Less than elevation 1,000m
Mounting direction	Free
Time rate	Continuously

■ **Materials**

- Brushes : Copper
- Rings : Copper alloy
- Brush springs : Spring steel
- Brush holders : Aluminum die-casting
- Rotational direction : CW-CCW
- Temperature range : -10°C~+50°C



SR

■ **Rated current:20A (Rated voltage:AC600V)**

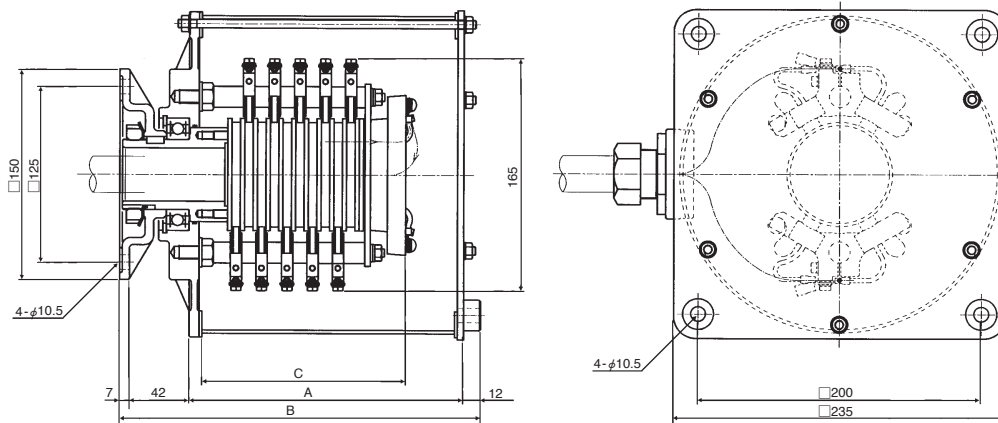

Model	Number of poles	Insulation resistance	Allowable rotation	Outside dimension (mm)			Mass kg
		MΩ (min)	min ⁻¹ (rpm)	A	B	C	
SR-1303	3	50	60	142	203	83	8.0
SR-1304	4			142	203	92	8.0
SR-1306	6			159	220	110	8.5
SR-1308	8			177	238	132	9.0
SR-1310	10			195	256	150	9.5
SR-1312	12			212	273	168	10.0
SR-1314	14			232	293	192	10.5
SR-1316	16			257	318	210	11.0
SR-1318	18			297	358	237	12.0
SR-1320	20			297	358	255	12.0
SR-1322	22			337	398	273	13.0
SR-1324	24			337	398	291	13.0
SR-1326	26			377	438	309	14.0
SR-1328	28			377	438	327	14.0
SR-1330	30			432	493	345	15.0
SR-1332	32			432	493	363	15.0

*Insulation resistance (MΩ) shall be the resistance measured at DC500V.

■ Rated current:50A (Rated voltage:AC600V)

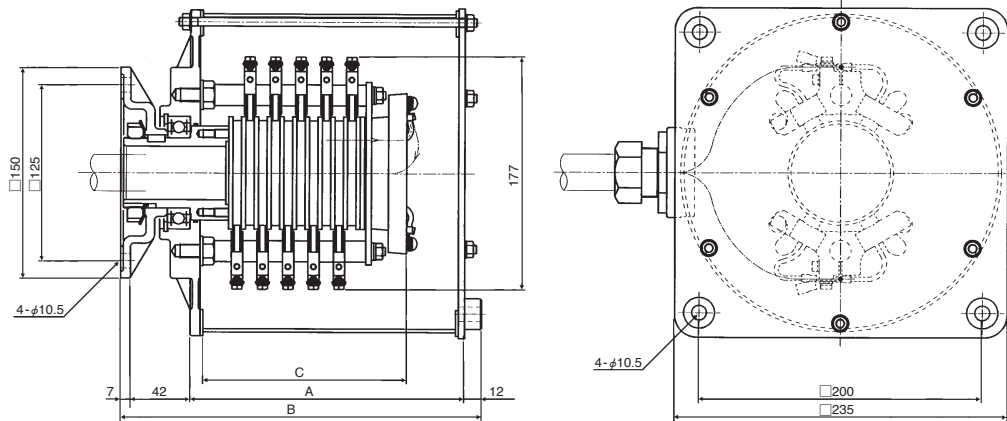

Model	Number of poles	Insulation resistance	Allowable rotation	Outside dimension (mm)			Mass kg
		MΩ (min)	min ⁻¹ (rpm)	A	B	C	
SR-3303	3	50	60	142	203	93.5	8.0
SR-3304	4			159	220	106.5	8.5
SR-3306	6			195	256	132.5	9.5
SR-3308	8			212	273	162.5	10.0
SR-3310	10			232	293	188.5	10.5
SR-3312	12			257	318	214.5	11.0

*Insulation resistance (MΩ) shall be the resistance measured at DC500V.

■ Rated current:100A (Rated voltage:AC600V)

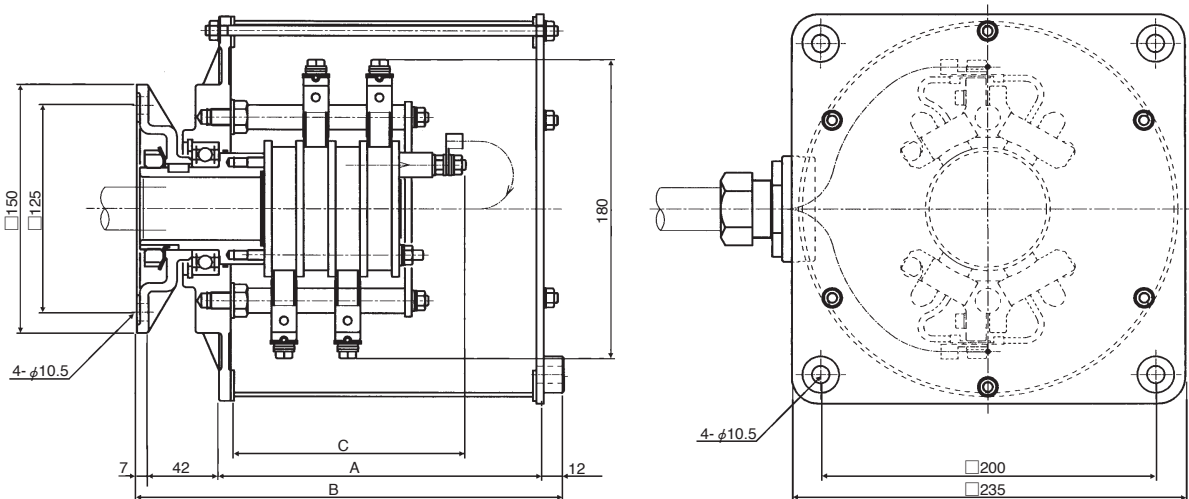

Model	Number of poles	Insulation resistance	Allowable rotation	Outside dimension (mm)			Mass kg
		MΩ (min)	min ⁻¹ (rpm)	A	B	C	
SR-4303	3	50	60	177	238	114.5	9.0
SR-4304	4			195	256	133.5	9.5

*Insulation resistance (MΩ) shall be the resistance measured at DC500V.

■ **Materials**

- Brushes : Copper
- Rings : Copper alloy
- Brush springs : Spring steel
- Brush holders : Aluminum die-casting
- Rotational direction : CW-CCW
- Temperature range : -10°C~+50°C



SR

■ **Rated current:20A (Rated voltage:AC600V)**

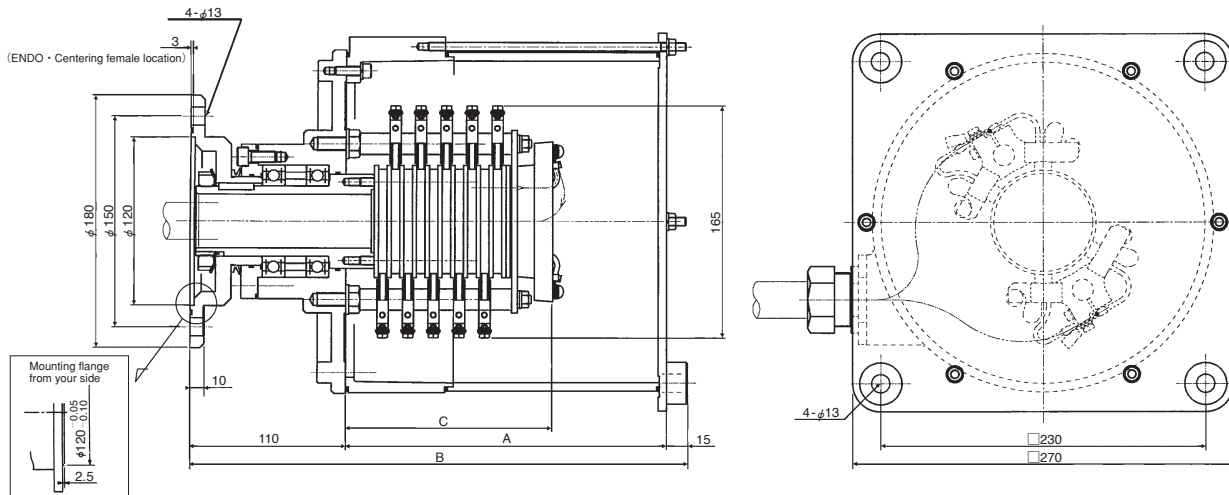

Model	Number of poles	Insulation resistance	Allowable rotation	Outside dimension (mm)			Mass kg
		MΩ (min)	min ⁻¹ (rpm)	A	B	C	
SR-1303-O	3	50	60	172	297	83	21.5
SR-1304-O	4			172	297	92	21.5
SR-1306-O	6			172	297	110	22.0
SR-1308-O	8			197	322	132	23.0
SR-1310-O	10			227	352	150	24.0
SR-1312-O	12			227	352	168	24.5
SR-1314-O	14			267	392	192	25.5
SR-1316-O	16			267	392	210	26.0
SR-1318-O	18			297	422	237	27.0
SR-1320-O	20			327	452	255	28.0
SR-1322-O	22			362	487	273	29.0
SR-1324-O	24			362	487	291	29.5
SR-1326-O	26			392	517	309	30.5
SR-1328-O	28			392	517	327	31.0
SR-1330-O	30			422	547	345	32.0
SR-1332-O	32	422	547	363	32.5		

*Insulation resistance (MΩ) shall be the resistance measured at DC500V.

■ Rated current:50A (Rated voltage:AC600V)

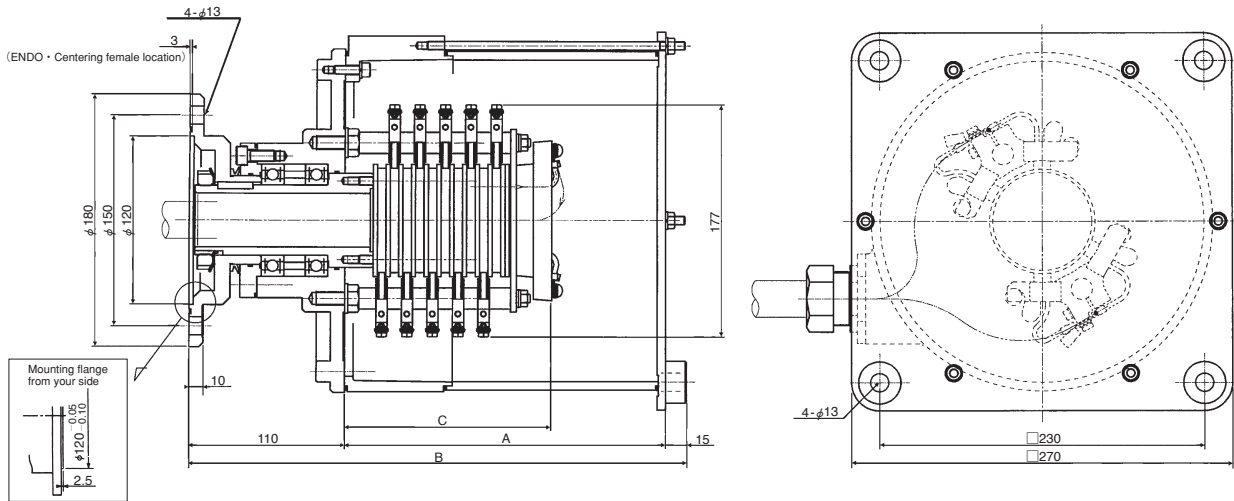

Model	Number of poles	Insulation resistance MΩ (min)	Allowable rotation min ⁻¹ (rpm)	Outside dimension (mm)			Mass kg
				A	B	C	
SR-3303-O	3	50	60	172	297	93.5	22.0
SR-3304-O	4			197	322	106.5	23.0
SR-3306-O	6			227	352	132.5	24.0
SR-3308-O	8			247	372	162.5	25.0
SR-3310-O	10			267	392	188.5	26.0
SR-3312-O	12			297	422	214.5	27.0

*Insulation resistance (MΩ) shall be the resistance measured at DC500V.

■ Rated current:100A (Rated voltage:AC600V)

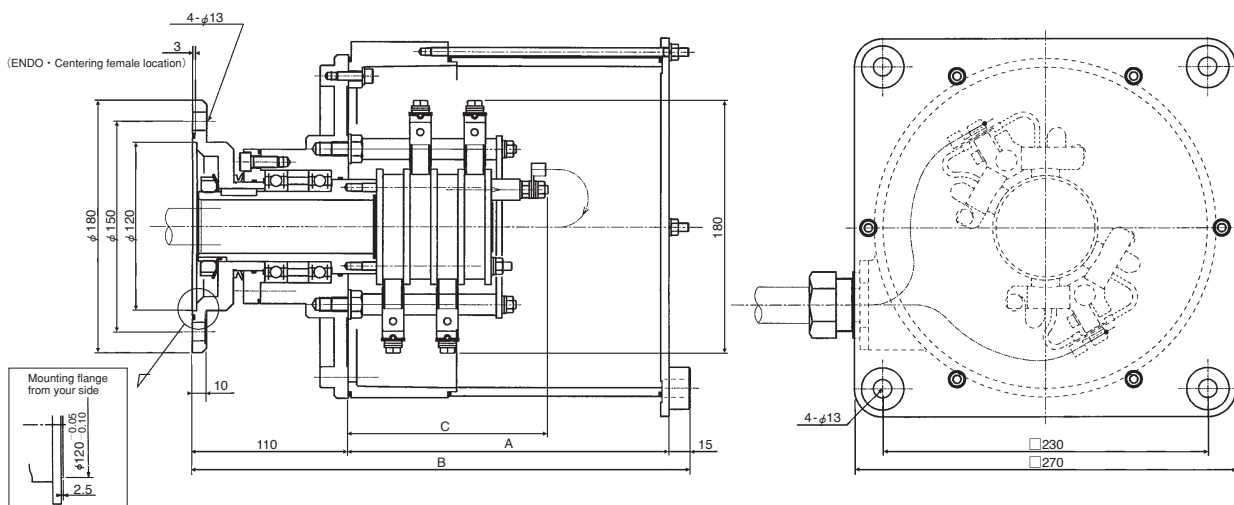

Model	Number of poles	Insulation resistance MΩ (min)	Allowable rotation min ⁻¹ (rpm)	Outside dimension (mm)			Mass kg
				A	B	C	
SR-4303-O	3	50	60	267	392	114.5	26.0
SR-4304-O	4			267	392	133.5	26.5

*Insulation resistance (MΩ) shall be the resistance measured at DC500V.

■ Slip ring for Communication, Control (SRP series)

No.	Item	Example of description	Requirements
1	Voltage	DC12V	
2	Current	0.1A	
3	No. of poles	4	
4	Rotational frequency	10min ⁻¹	
5	Standard	RS-422	
6	Application	Sensor	
7	Surroundings, Temperature	Indoor, +40°C	
8	Other requirements		
9	Quantity		
10	Delivery		

■ Slip ring for Power, Control (SR series)

No.	Item	Example of description	Requirements
1	Cable type	2PNCT	
2	Cable cross section	2mm ²	
3	Number of conductor	10	
4	Voltage	AC200V, 50Hz	
5	Current	10A	
6	No. of poles	10	
7	Rotational frequency	1min ⁻¹	
8	Application	Jib crane	
9	Surroundings, Temperature	Indoor, +40°C	
10	Other requirements		
11	Quantity		
12	Delivery		

■ Installation

 A B C		
--	--	--

■ Please fill the below blanks and send inquiry for us.

Company name

Name

TEL

FAX

E-mail

Please contact to : **ENDO KOGYO CO., LTD.**

3-14-7, Akibacho, Tsubame, Niigata, Japan TEL: +81-256-62-5133 FAX: +81-256-62-5772

We offer wide range of slip ring in accordance with various standard.

Nowadays the potential areas of slip ring applications are very huge. We can also offer multiplex slip ring with power supplying and communication control for machines with rotational movement. We would also be happy to design and build special units depend on your particular requirements.

■ Example of Multiplex slip ring

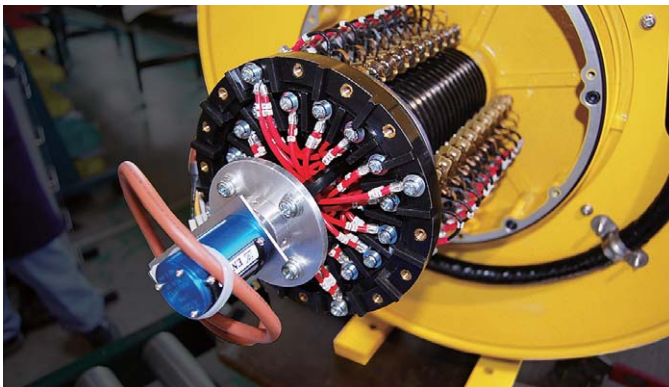

AC600V-20A-30P+SRP-CL4

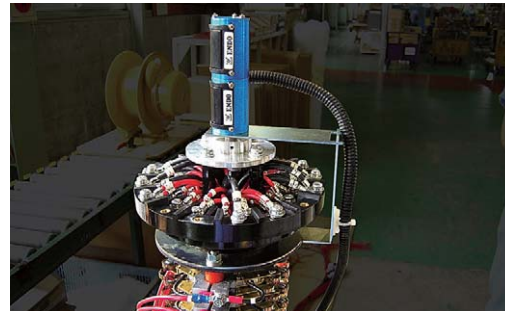

AC600V-30A-8P+10A-20P+SRP-300312S

Multiplex



AC600V-200A-4P+20A-18P

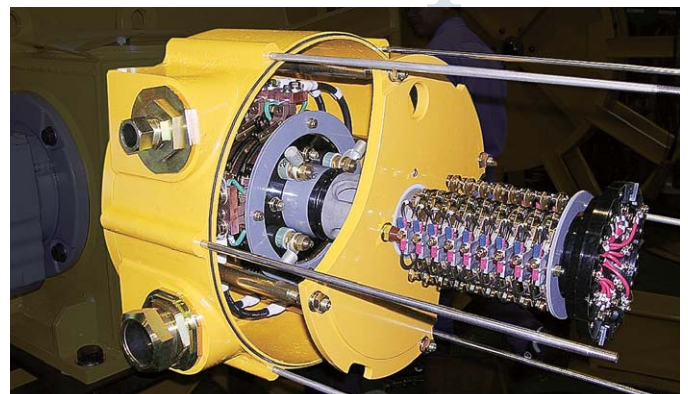

AC600V-20A-8P+SPM-50-16P-02

■ Special slip ring

Special

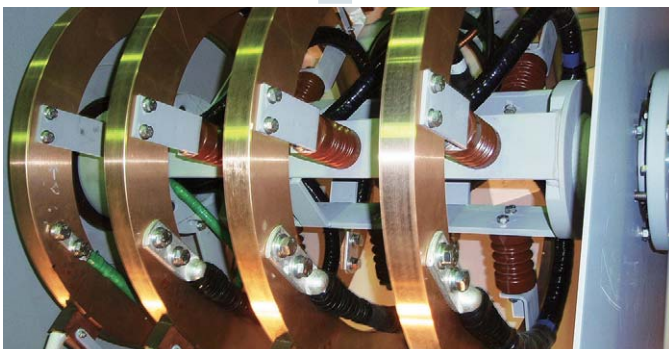

AC6600V-670A-3P+E



300A-8P 30A-51P 20A-36P CC-Link

SLIP RING

ENDO ENDO KOGYO CO., LTD.

3-14-7, Akibacho, Tsubame, Niigata, Japan
TEL : +81-256-62-5131 FAX.+81-256-62-5772

<http://www.endo-kogyo.co.jp>

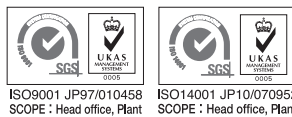

ENDO ENDO KOGYO INDIA PVT. LTD.

101, First Floor, Aditya Towers
LullaNagar, Off Kondhwa Road, Pune - 411 040
TEL : +91-86-00042752 Mail.info@endo-india.co.in

<http://www.endo-india.co.in>

*Items shown in this catalogue are subject to change without notice. Please note we have no responsibility for missing and fault on this printing.

Published in September 2016